



# 2018

## SUPPLEMENTARY REGULATIONS

<i>ARTICLE 1 – ORGANISATION</i>	<i>1</i>
<i>ARTICLE 2 – ENTRIES</i>	<i>1</i>
<i>ARTICLE 3 – ELIGIBLE CARS</i>	<i>1</i>
<i>ARTICLE 4 – TECHNICAL REGULATIONS</i>	<i>2</i>
<i>ARTICLE 5 – TECHNICAL &amp; ADMINISTRATIVE CHECKS</i>	<i>2</i>
<i>ARTICLE 6 – CREW</i>	<i>2</i>
<i>ARTICLE 7 – BRIEFING</i>	<i>2</i>
<i>ARTICLE 8 – PRACTICES- RACE</i>	<i>2</i>
<i>ARTICLE 9 – STARTING GRID</i>	<i>3</i>
<i>ARTICLE 10 – STARTING PROCEDURE</i>	<i>3</i>
<i>ARTICLE 11 – PIT STOPS</i>	<i>3</i>
<i>ARTICLE 12 – NEUTRALISATION - SAFETY CAR – RED FLAG</i>	<i>4</i>
<i>ARTICLE 13 – FINISH</i>	<i>4</i>
<i>ARTICLE 14 – CLASSIFICATION – PODIUM</i>	<i>5</i>
<i>ARTICLE 15 – AMENDMENT TO THE COMPETITION, CANCELLATION OF THE EVENT</i>	<i>5</i>

## ARTICLE 1 – ORGANISATION

Peter Auto will organise in 2018 an FIA International Series of 5 races. These races will be organised according to the International Sporting Code, particularly to Appendix K, as well as to the Sporting Regulations of the FIA.  
These Regulations have been approved by the FIA under organisation permit N° IS.14-2018

The official name of the series is **THE GREATEST'S TROPHY.**

**Official Language:** Only the French text approved by the FFSA is binding

### Officials

#### A. Permanent officials:

Peter Auto will designate the permanent officials of the series who will officiate on all races:

Panel of the Stewards	President	Emile PRADES	Lic 2247 ASA : 0703
	Member	TBC	TBC
	Member	TBC	TBC
Race director		Patrick MORISSEAU	Lic 28737 ASA : 1201
Deputy race director		TBC	TBC
Chief Scrutineer		TBC	TBC
Scrutineer		TBC	TBC
Competitors Relations Officer		TBC	TBC

#### B. Non-permanent officials:

The following officials will be proposed by the ASN and selected by Peter Auto in conjunction with the request to organise a race:

- A Steward will be chosen from the licensed members of the ASN of the country hosting the race.
- A Clerk of the Course
- A Competitors Relations Officer

#### C. Scrutineers

The chief scrutineer will be in charge of the scrutineering and will have full authority over the national scrutineers (under national ASN and organisers' approval). Therefore the chief scrutineer may check and scrutineer a car/entrant at any time during the event.

## ARTICLE 2 – ENTRIES

✧ **The season entry fee (5 races) €11,000** (= €14,6/min) must be sent to the Organisers before the **15/02/2018\***.

✧ **The race by race entries** must be sent to the Organisers at least one month before each race\*

(€ 2,500 by race + € 500 for administration fee at the first race)

✧ To be considered, entries must:

- include the entry fee,
- **include the full color copy of the valid FIA International HTP papers,**
- include a copy of the drivers' licences,
- be sent to: The Greatest's Trophy – Peter Auto - 103, rue Lamarck – F-75018 Paris – France

**\*The deadlines are subject to be put off. The selection of the cars is at the Organisers' sole discretion.**

**The spirit of historic racing and the principles of the Gentleman Drivers should be respected both on and off track. Unrespectful behaviour can lead to the team and/or driver being punished or excluded from the Peter Auto events upon Stewards' decision.**

## ARTICLE 3 – ELIGIBLE CARS

A/ Pre-1966' Sportscars and Grand Tourisme cars with exceptional record, pedigree and/or historic.

All cars shall conform to the 2018 FIA Appendix K requirements and have a valid Historic Technical Passport (HTP).

Cars built before 1966 but with technical evolutions from G1 period (1966-1969) could be accepted.

To preserve the cars' security during the race and the exclusive nature of the grid, the number of entrants will be limited to 30 to 35 cars maximum regarding the track homologation.

#### B/ Change of car during a meeting: upon Stewards' approval.

Provided it has successfully undergone the technical scrutineering, a "Reserve car" can be accepted.

A written request must be submitted to the Clerk of the Course for approval from the Stewards.

This request must be done at least:

- 2 hours before the start of the first qualifying.
- 2 hours before the start of the second qualifying (the time from qualifying will be cancelled)
- 2 hours before the start of the race (the car will start from the back of the grid).

## ARTICLE 4 – TECHNICAL REGULATIONS

 See Greatest's Trophy Technical Regulations. (Appendix 1)  
**Iso A3/C are subject to a specific Peter Auto regulation (available on request).**

All cars to be presented to the scrutineers should comply with their period specification as well as their HTP specification. All competitors will have to certify and sign an "engine capacity and weight" statement.

Weight and engine capacity may be checked at any time during the event at the discretion of the Chief Scrutineer or on Stewards decision. If a car does not comply with the technical regulations or its HTP, the absence of a gain in performance will not be considered as a valid argument.

Drivers' equipment must conform to Appendix L of the 2018 International Sporting Code.

## ARTICLE 5 – TECHNICAL & ADMINISTRATIVE CHECKS

The following documents shall be presented during the verification:

✧ FIA International Drivers licence

A national highest grade licence will be accepted for entrants racing in their own country providing the licence has been issued by the organising ASN.

✧ **Valid International FIA Historic Technical Passport (HTP):**

The Organisation can allow a car to race which HTP papers are being issued  
Nationals HTPs are not accepted.

✧ The stickers (race numbers, sponsors) provided during the administrative checks by the Organisers must be displayed on the car without cutting (except for justifying reasons).

✧ Cars with period record could ask to keep their period race numbers (if the number is available). The request has to be done at the inscription and the race numbers have to appear on the HTP.

✧ Any additional advertising (save the original livery of the car) must meet the FIA Appendix K Art. 2.1.9 requirement.

✧ Any other additional advertising (save the original livery of the car) should receive the Organiser's written agreement. Entrants' brands and sponsors competing with the official sponsors of the grid could be refused.

✧ **Windshield stickers are forbidden (save the original livery of the car),**

 Any car found in breach of the above "advertising" regulations will not be able to start the race,

✧ Scrutineering will be considered as an implicit statement of the car's conformity and eligibility to the present regulation,

✧ All competitors will have to provide a validity certificate of the safety fuel tank(s) at the first event,

✧ A 2KG fire extinguisher will be mandatory in the paddock for every car,

✧ The use of an head restraint device (RFT/FHR) like HANS is strongly recommended. It is mandatory to use narrow shoulder harness (2"/52 mm wide) only with RFT/FHR device and with appropriate helmet.

✧ Onboard cameras:

The Organization reserves the right to install one or more onboard cameras inside or outside the cars. The collected images may be used by the Organization for promotional purposes and broadcasted without the agreement of the competitor and / or drivers on social networks, websites or any other means chosen by the Organization.

The Organization reserves the right to recover the images recorded by the onboard cameras installed by the teams. The collected images may be used by the Organization for promotional purposes and broadcasted without the agreement of the competitor and / or drivers on social networks, websites or any other means chosen by the Organization.

## ARTICLE 6 – CREW

✧ The crew can consist of one or two driver(s). In this case, they will be designed as "Pilote 1" and "Pilote 2"

✧ In case of a two drivers crew, each driver will have to enter a 35 minutes race.

✧ A professional driver, driving someone else's car alone, may be on the podium but cannot score any point towards the final season classification.

**Change of driver during a meeting: upon Stewards' approval.**

✧ Provided he has the proper licence and satisfied the administrative requirements, an additional driver or a change of the crew is authorised. A written request must be submitted to the clerk of the course for authorisation by the Panel of the Stewards at the latest 2 hours before the start of the first qualifying.

✧ Provided he has participated in the qualifying sessions, a driver may be registered as a second driver on another qualified car. A written request must be given to the Clerk of the Course for authorisation at the latest 2 hours before the start of the race.

## ARTICLE 7 – BRIEFING

✧ It is mandatory for all drivers to attend the Drivers' Briefing.

✧ Any driver missing the briefing could receive a €100-penalty and could be excluded from the starting grid by decision of the Panel of the Stewards.

## ARTICLE 8 – PRACTICES- RACE

 No aggressive or dangerous behaviour will be accepted on track!

A driver who is judged to be dangerous, may be excluded from the race, and/or the following races by the Panel of the Stewards, with no refund of entry fees.

Any contact between two cars on track, at any time during the meeting, will be subject to a Stewards' investigation.. They will have the right to determine the responsible driver(s), who might be inflicted a penalty upon decision of the Panel of the Stewards. In any case the cars should be inspected again by the technical scrutineer.

Only cars and drivers that have completed the Technical and Administrative Checks will be accepted in the practice sessions. The competitor responsible of the damages caused deliberately to another car may be asked by the Organization to bear the reparation costs up to 50% of the total amount.

- There will be one 40' free practice session.
- There will be one 40' qualifying practice sessions.
- There will be two 35' race.
  
- Non-respect of the racing line:
  - During the practice:
    - 1<sup>st</sup> breach: Warning.
    - 2<sup>nd</sup> breach: Cancellation of the best time achieved during the concerned session.
    - 3<sup>rd</sup> breach: Cancellation of all times achieved during the concerned session.
  - During the race:
    - 1<sup>st</sup> breach: Warning.
    - 2<sup>nd</sup> breach: +45 seconds to the final race time.
    - 3<sup>rd</sup> breach: +1 minute to the final race time.
  
- It is forbidden to pass any car after taking the chequered flag during practice or races.
  - Practice: Cancellation of the best time achieved during the concerned session.
  - Race: +45 seconds to the final race time.
  
- It is forbidden to pass twice the chequered flag during practice or races.
  - Practice: Cancellation of the best time achieved during the concerned session.
  - Race: +45 seconds to the final race time.

## **ARTICLE 9 – STARTING GRID**

- ✧ Race 1 - According to qualifying session / Race 2 – According to Race 1 classification.
- ✧ It will be in a 2x2 in line position. Each driver must keep the line (inside or outside) he had in the formation lap until he passes the timekeeping line.

## **ARTICLE 10 – STARTING PROCEDURE**

- ✧ The start will be a rolling start.
- ✧ The cars will leave the pre-grid and do a formation lap and stop on the starting grid. If needed, the Clerk of the Course is entitled to allow additional formation laps.
  - 5 minutes board + Horn before the formation lap start:
  - 3 minutes board + Horn before the formation lap start:
  - 1 minute board + Horn = Evacuation of the grid.
  - 30 seconds before the formation lap starts: "30 seconds" board + Horn.
  - Green Flag:
    - Start of the formation lap behind the pace car; the cars shall keep to their positions and remain in a single file one after the other in the two formed rows.
    - When the lights of the pace car are switched off, it is forbidden to zigzag. Cars must stay in two rows.
  - The cars will follow the leading car at an average of 70km/h up to 90 km/h.
  - The red light will be switched on during the formation lap.
  - The start of the race will be given with the green light on.
  - Overtaking is not permitted before the car has crossed the timekeeping line.
    - Penalty – 60 seconds per overtaken position to be added to the race time.

## **ARTICLE 11 – PIT STOPS**

### **Speed limit in the pitlane.**

The speed limit in the pitlane will be announced during the Drivers' briefing.

Pitstop is not mandatory. Change of driver is forbidden during race.

- Penalties
  - a) Free Practices:
    - \* 1<sup>st</sup> infringement: a 30-second stop in the Stop and Go zone, engine running
    - \* 2<sup>nd</sup> infringement: a 2-minute stop in the Stop and Go zone, engine switched off
    - \* 3<sup>rd</sup> infringement: At the Panel of the Stewards' sole discretion (possible exclusion).
  - b) Qualifying Practices:
    - \* 1<sup>st</sup> infringement: Cancellation of the best time achieved during the concerned session.
    - \* 2<sup>nd</sup> infringement: Cancellation of all times achieved during the concerned session.
    - \* 3<sup>rd</sup> infringement: At the Panel of the Stewards' sole discretion (possible exclusion).
  - c) Race: To the Panel of the Stewards discretion.

## **ARTICLE 12 – NEUTRALISATION - SAFETY CAR – RED FLAG**

### **12.1 – Responsibility:**

The Clerk of the Course is solely entitled to decide upon the neutralisation of the race using the "Safety-Car" procedure.

### **12.2 - Identification of the "Safety-Car":**

a/ A "Safety-Car" is used on the racetrack;

b/ The "Safety-Car" bears on the boot and on each side a "Safety-Car" inscription

### **12.3 - Procedure:**

12.3.1 – On the order of the Clerk of the Course, all Marshals will display waved yellow flags until the end of the "Safety-Car" intervention. Flashing yellow lights will be switched on at the starting grid and along the track;

12.3.2 – From the beginning of the intervention on, an "S.C." ("Safety-Car") board will be presented at each post;

12.3.3 – The "Safety-Car", yellow flashing lights switched on, will penetrate onto the track, preferably ahead the leading racing car. All the racing cars shall line up behind the "Safety-Car";

12.3.4 – All competing cars will form up in line behind the Safety Car no more than 5 cars lengths apart. Any overtaking on the track is forbidden, unless a car is signalled to do so by the Safety Car.

12.3.5 – The pit lane exit will be closed and reopened a few seconds after the group of cars following the Safety Car has passed the pit exit.

### **12.4 – Pit Stops:**

12.4.1 – During the "Safety-Car" intervention, the racing cars are allowed to make a pit stop but may only re-join the race when lights at the end of the pit lane are green after the last car queuing behind the "Safety-Car" has passed.

12.4.2 – A car re-joining the race will catch up to the line of cars following the "Safety-Car".

### **12.5 – End of Intervention:**

12.5.1 – The end of the "Safety-Car" procedure is under the Clerk of the Course's sole responsibility.

12.5.2 – When the Clerk of the course calls in the Safety Car, the latter will extinguish its lights. This will be the signal to the drivers that it will leave the track to the pit lane at the end of that lap. At this point the first car in line behind the Safety Car may dictate the pace and, if necessary, leave more than 5 cars lengths behind the following car. As the Safety Car is approaching the pit lane, the yellow flags and the "SC" boards at the Marshals posts will be withdrawn and waving green flags will be displayed for no more than one lap.

12.5.3 – Overtaking is strictly prohibited until the cars go through the green lights/flags located on the timekeeping line.

12.5.4 – Each lap achieved during the "Safety-Car" procedure is considered as part of the race.

### **12.6 – Red flag:**

Before the end of the second lap, and for any reason, if the race is interrupted, the red flag will be shown waved to competitors. Vehicles resumed their places on the starting grid according to the original starting grid.

After more than 2 laps and less than 75% of the race, cars stop in front of the starting line at the location indicated by the marshals, then resumed their places on the starting grid according to the classification before stopping.

In both cases, interventions on cars are only allowed to the presentation of the sign "Stop Engine" and the process resumes at the presentation of the panel "Engine".

### **12.7 - Yellow flag:**

A waved yellow flag is shown to the drivers on the instructions of the Race Director. The yellow flag indicates a danger. It can be shown in two distinct manners:

- One waved yellow flag: Danger on the side of the track: reduce speed, overtaking is prohibited, be prepared to change direction,
- Two waved yellow flags: Danger on the track, marshals working on the track: reduce speed drastically, overtaking is prohibited, be prepared to change direction or stop.

Overtaking are strictly prohibited between the first yellow flag and the green flag waved after the incident area.

### **12.8 –Full Course Yellow:**

Only during practice or qualifying session:

Should it be necessary for safety reasons, whenever a car is stopped in a dangerous location, whenever track vehicles are working near the track, marshals are working close to the track or other similar situations, the Race Director will declare a Full Course Yellow period. The message FCY will be displayed on the monitors. Waved yellow flags and FCY boards will be shown at all marshal posts, at the Line and at pit exit. All cars must immediately slow down to 80 km/h (or 60 km/h if needed). Overtaking, except for safety reasons accepted as such by the Race Director or Stewards of the Meeting, is forbidden. Cars must proceed at a constant speed in single file. Speeds will be monitored and any car exceeding the given speed will be reported to the Stewards of the Meeting and a penalty may be given. The pit lane entry and exit will remain open. Cars entering the pit lane may overtake cars that are on the track once they cross Safety Car Line 1. Cars exiting the pit lane may overtake other cars until they reach Safety Car Line 2. Once the problem is resolved, the track will return to Green and the information will be given on the monitors. Alternatively, should the problem not be resolved, the Safety Car may be deployed.

## **ARTICLE 13 – FINISH**

The Chequered Flag will be presented to the leading car after 35 minutes of race.

#### **ARTICLE 14 – CLASSIFICATION – PODIUM**

*A podium celebration will take place for the scratch finishers at the end of each race.*

- *The three first cars of the scratch classification.*
- *The three first cars of the performance index (see appendix 3).*
- *The first of “drum brakes” category.*

*To be part of the classification, the car must cross the finish line under the **chequered flag**.*

*A general prize giving ceremony will be held at the end of the year.*

#### **ARTICLE 15 – AMENDMENT TO THE COMPETITION, CANCELLATION OF THE EVENT**

*The Organization reserves the right to undertake all necessary changes to the competition due to force majeure or for safety reasons or ordered by the authorities or also to cancel the event or individual competitions, if this is determined by extraordinary circumstances, with no refunds of entries.*

# APPENDIX 1

## 2018 Greatest's Trophy Technical Regulations

We would like to remind you that the cars should be raced in their original period specifications.

Period specification and conformity are the fundamentals of our races.

Checks (weight, engine capacity, ride height,...) will be done throughout the year to ensure a sporting equity for all competitors.

A penalty system will allow entrants to compete if found in breach of the regulations (except for safety devices) without perturbing the results.

All penalties will be followed by a delay for the car to be put in conformity.

In cases of non-compliance with the previous statement made by the scrutineers, penalties can be strengthened and can lead to the exclusion of the entrant/car.

### 4.1 Tyres

**Will only be accepted:**

**Exclusively** ➤ Racing tyres with treaded pattern. All over the width.

Ex: Avon CR6ZZ, Dunlop CR65 L section ONLY...

Rain Tyres are forbidden. Post 1981/Modern design treaded tyres are forbidden.

### 4.2 Engines and capacity

Cars should be presented using their period engine specification and should meet the specification of their HTP.

All cars presented in a **more modern configuration** than the class limit of the following regulation, the car will be classified in the upper class or excluded if not possible.

### 4.3 Lightings

Every car must be fitted with **period** type of lights in running order conditions (incandescent lamps only, leds or xenons are forbidden).

**It is mandatory for Period E cars to use a dynamo system (Alternators being FORBIDDEN).**

A rain light approved by the FIA (Technical List No. 19) or complying with ECE R38 road standard (or at least equivalent to standards of another country) is required. Location: rear window, tailgate, trunk lid, in the longitudinal axis of the car.

### 4.4 Weight

Whenever the car is checked, throughout the event, the weight should never be inferior to the homologation weight or to the weight stipulated in the Peter Auto Specific Regulations for Jaguar E Type, Cobra or ISO.

If the weight of a car is close to the minimum weight, the fuel will be removed from the car for another weight check.

Some ballast can be fixed in the car to meet the target weight, provided it is a solid and visible bloc fixed on the floor of car and sealed by the technical scrutineer. A spare wheel can be used as ballast.

### 4.5 Ride height

**Reference : Appendix K 2018 – Appendix VII – 10.2**

✧ Chassis

- GT and GTS classes : 100mm minimum, without exhaust system
- GTP and TSRC classes : 80mm minimum, without exhaust system

✧ Exhaust : pipes and silencers

- GT and GTS classes : 70mm minimum
- GTP and TSRC classes : 50mm minimum

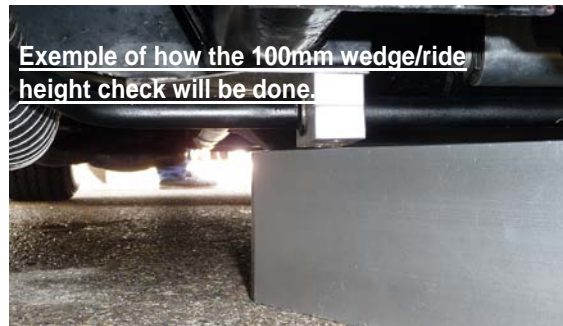

Measuring area:

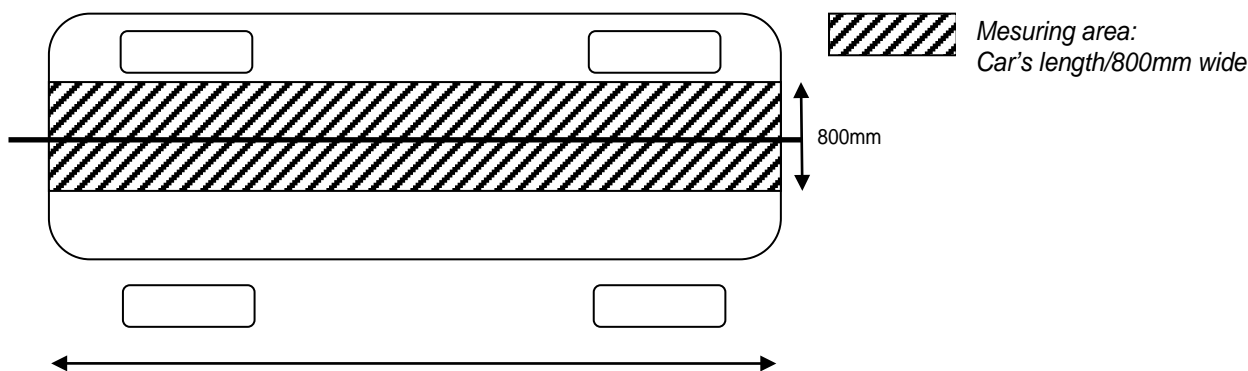

#### 4.6 Sound limit

The noise of the car should not exceed the 105 dB(A) limit (with or without silencer) at three quarter of the maximum rev-limit **during the whole season**. The noise check will be done according to the following FIA method:

- 1-The measurement point will be situated 50cm from the exhaust pipe , at an angle of 45° from the pipe axle.
- 2- The microphone will be located at a height between 50cm and 1meter from the ground.
- 3- The engine should run at three quarter of its maximum rev-limit.

In the case of a competitor finding it impossible to respect the enforced noise limit, it is mandatory for them to contact and inform the Organization **at least a month before the event** and propose a motivated and detailed alternative. The Organization reserves the right to authorize a single derogation if the alternative is understood to be justified. The competitor will be informed of the decision.

#### 4.7 Communication system

No communication system but pit boards between the pits and the driver will be allowed.

Penalties:

- Practice: Cancellation of the best time achieved.
- Race: +1 Lap

#### 4.8 Transponder

Each car registered for the full season must be fitted with an AMB transponder.

#### 4.9 Onboard cameras

The installation of onboard cameras is authorized but must follows the guidelines of the FFSA 2018 Technical Regulations.

Inboard camera:

The fixation must be rigid, positioned in the rear and between the seats



For « Pen » type cameras, it can be mounted on the front upright of the roll cage, the control unit must be fixed on the floor, behind the seats.





Only « Pen » type cameras will be accepted outside the car, positioned inside the perimeter of the car. Fixation must be from a mechanical type, and if a support is needed, it cannot exceed 40 mm height. Control unit must be fixed on the floor, behind the seats for touring cars or under the seats for the twin seaters. Fixation must be from a mechanical type, tape or velcro are forbidden.

Open cars

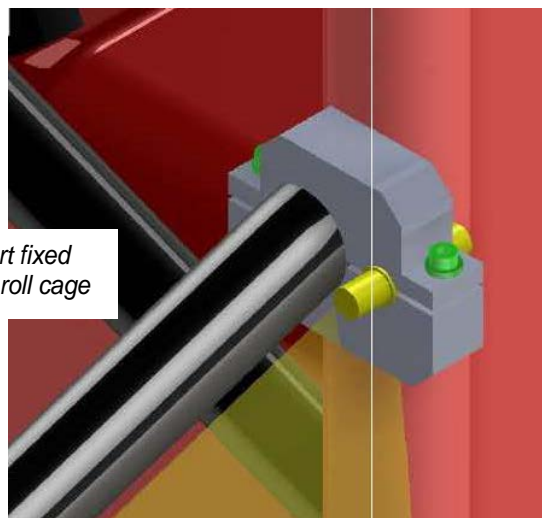
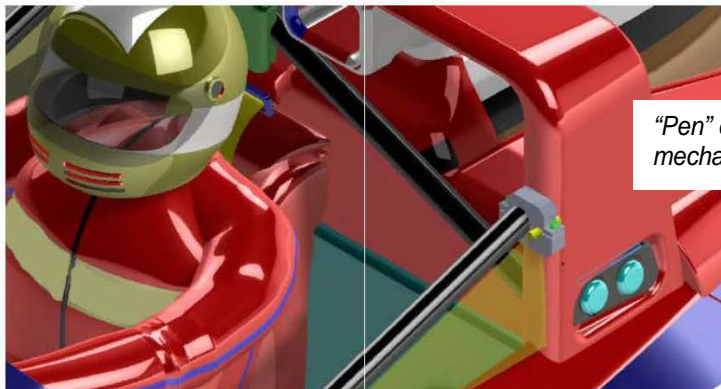

Closed cars

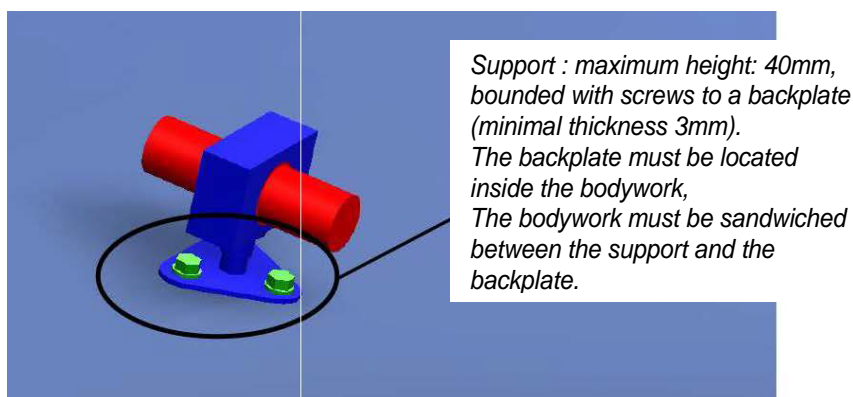
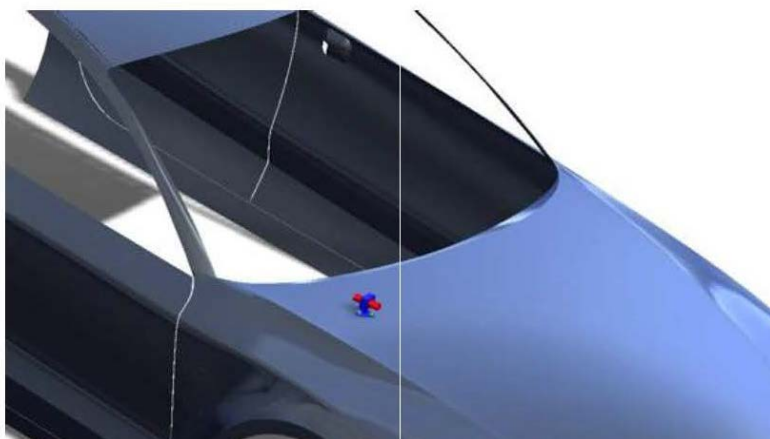

# FORBIDDEN FIXATIONS



# PENALTIES BOARD – 2018 GREATEST’S TROPHY

*All penalties cited below are the one presented in the present supplementary regulations. All of them will be applied by Race Control without notification unless they are modified by the Panel of the Stewards. Any penalty not figuring in the supplementary regulation or below will be decided to the sole discretion of the Panel of the Stewards.*

Article	Description	Session	Penalty
<b>SPORTING</b>			
2. Entries	Non-respect of historic racing spirit		Can lead to exclusion
5. Advertising	Non-respect of advertising rules		Race start refusal
7. Briefing	No show		Race start refusal
8. Practices and Race	Non-respect of the racing line	Practice	1 <sup>st</sup> breach - Warning 2 <sup>nd</sup> breach – Cancellation of the best time 3 <sup>rd</sup> breach – Cancellation of all time
		Race	1 <sup>st</sup> breach - Warning 2 <sup>nd</sup> breach – +45 seconds to the final race time 3 <sup>rd</sup> breach – +1 minute to the final race time
	Overtaking after chequered flag	Practice	Cancellation of the best time
		Race	+45 seconds to the final race time
10. Starting procedure	Overtaking before timekeeping line	Race	60 seconds per overtaken line
11. Speed limit/Pitlane	Speeding in the Pitlane	Practice	1 <sup>st</sup> breach – 30s stop in the stop&go zone – Engine on 2 <sup>nd</sup> breach – 2m stop in the stop&go zone – Engine off 3 <sup>rd</sup> breach - According to the panel of the stewards decision
		Qualifying	1 <sup>st</sup> breach – Cancellation of the best time 2 <sup>nd</sup> breach – Cancellation of all time 3 <sup>rd</sup> breach - According to the panel of the stewards decision
		Race	According to the panel of the stewards decision
<b>TECHNICAL</b>			
4.6 Sound limit	Noise >105db		Can lead to exclusion
4.7 Communication systems	Except pit boards : Forbidden	Practice	Cancellation of the best time
		Race	1 Lap

*For any offense, stewards may decide to withdraw season ranking points instead of a sporting penalty*

## APPENDIX 2

# 2018 Greatest's Trophy Points allocation / Season Classification

### There will be 2 classifications at the end of the season

- One Scratch classification
  - One Index of Performance classification
- To be part of the classification, the car must cross the finish line under the chequered flag.
- Points are allocated to the team.
- Each driver taking part in a race automatically scores ranking points corresponding to the numbers of cars which have effectively started the race (limited to 20 cars max). Each car taking part in the practice session or qualifying session but not in the race scores half of these points (maximum 10 points).
- In case of penalty, these starting points will revert to the car. Only classification points can be withdrawn.
- In case of race interruption, for any reason, if the winner did not drive a minimum of Y laps, points will be allocated up to 50% of the scale.

With  $Y = \frac{\text{Initial duration of the race}}{\text{Qualifying time of the winner} \times 2}$

- For each race, first ten in scratch and index classifications score points for season classification according to the grid below.

**EXAMPLE: The second in a race of 42 cars scores 20+18 points = 38 points (except bonus points).**

Position	Starting points (= starting cars, limited to 20)	Classification points	Total (without bonus points)
<b>1st</b>	<b>20</b>	<b>20</b>	<b>40</b>
<b>2nd</b>	<b>20</b>	<b>18</b>	<b>38</b>
<b>3rd</b>	<b>20</b>	<b>16</b>	<b>36</b>
<b>4th</b>	<b>20</b>	<b>14</b>	<b>34</b>
<b>5th</b>	<b>20</b>	<b>12</b>	<b>32</b>
<b>6th</b>	<b>20</b>	<b>10</b>	<b>30</b>
<b>7th</b>	<b>20</b>	<b>8</b>	<b>28</b>
<b>8th</b>	<b>20</b>	<b>6</b>	<b>26</b>
<b>9th</b>	<b>20</b>	<b>4</b>	<b>24</b>
<b>10th</b>	<b>20</b>	<b>2</b>	<b>22</b>
<b>11th</b>	<b>20</b>	<b>0</b>	<b>20</b>

Bonus classe « Drum Brakes »	Bonus classe « 1 <sup>st</sup> Under 2 liter »
	<i>At least three cars entered in class at the start</i>
1st = 3 pts	1st = 3 pts
2nd = 2 pts	
3rd = 1 pt	
<b>Scratch Only</b>	<b>Scratch Only</b>

- Bonus points awarded to the two classes can't be combined.

**Index of Performance – Formula:**

$$\left[ \frac{\text{Scratch time competitor}}{\text{Number of laps achieved by the competitor or retained after application of eventual penalties}} \right] \times \text{Number of laps achieved by overall winner} \times \text{Index} = \text{Result}$$

- At the end of the season the **three best drivers** in each **2 classifications** will get an award during a prize giving ceremony.